



HEAVY DUTY

JHD1130WP

AM/ FM/ WB/ AUX-IN Heavy Duty Radio

Installation and Operation Manual

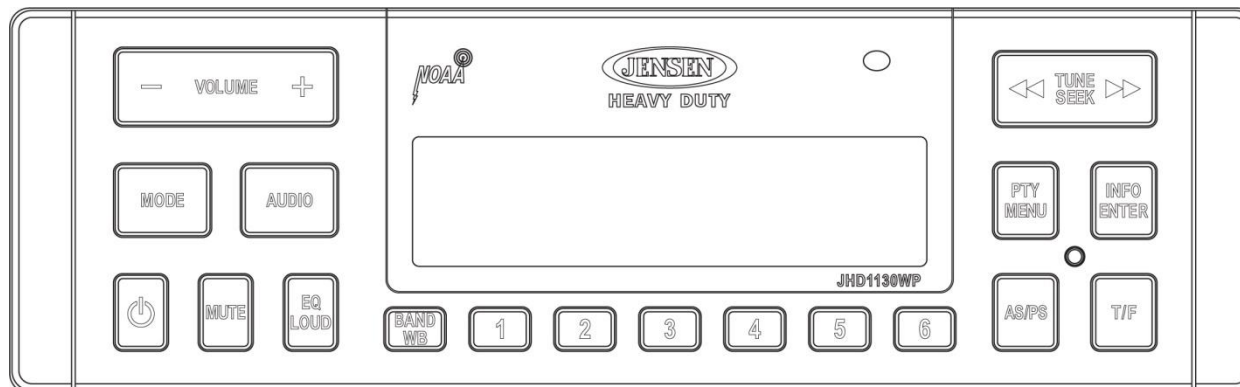

CONTENTS

Introduction.....	1
Safety Information	2
Installation	3
Wiring.....	4
Basic Operation	5
Tuner Operation.....	7
Care and Maintenance	9
Troubleshooting.....	9
Specifications	10

INTRODUCTION

System Features

Features of Jensen JHD1130WP mobile audio system include:

- 10 Character Alpha-Numeric Segmented LCD
- AM/FM US/EURO Tuner with 30 Presets (12 AM, 18 FM)
- RBDS (Radio Broadcast Data Service) with PTY Search
- Weatherband Tuner
- Mute
- Pre-set Equalizer - 5 settings (Flat, Rock, Pop, Classical, User)
- Electronic Bass, Treble, Balance and Fader Controls
- Output Power RMS 15W x 4
- Clock 12/24 Hour Selectable
- IR Wireless Remote Control Ready (sold separately)
- 2-Wire Power with Non-Volatile Memory and Clock/Time Support
- Auxiliary Audio Input (Rear RCA)

Content List

- Jensen Heavy Duty Radio
- Hardware Kit
- 10AMP Fuse
- Installation Manual
- Quick Reference Guide

HARDWARE KIT CONTENTS

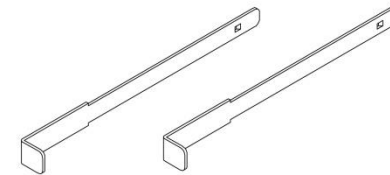

DIN SLEEVE
REMOVAL TOOL

SAFETY INFORMATION

When Driving

Keep the volume level low enough to be aware of the road and traffic conditions.

When Washing Your Vehicle

Do not expose the product to water or excessive moisture. Moisture can cause electrical shorts, fire or other damage.

When Parked

Parking in direct sunlight can produce very high temperatures inside your vehicle. Give the interior a chance to cool down before starting playback.

Use the Proper Power Supply

This product is designed to operate with a 12 volt DC negative ground battery system.

WARNING:

- TO REDUCE THE RISK OF FIRE OR ELECTRIC SHOCK, DO NOT EXPOSE THIS EQUIPMENT TO RAIN OR MOISTURE.
- TO REDUCE THE RISK OF FIRE OR ELECTRIC SHOCK AND ANNOYING INTERFERENCE, USE ONLY THE RECOMMENDED ACCESSORIES.

INSTALLATION

This unit is designed for installation in vehicle cabs with an existing 1-DIN radio opening. In many cases, a special installation kit will be required to mount the radio to the dashboard. See the dealer where the radio was purchased for kit availability. Always check the kit application before purchasing to make sure the kit works with your vehicle.

Before you Begin

1. Disconnect Battery
Before you begin, always disconnect the battery negative terminal.
2. Remove Transport Screws

Important Notes

- Before final installation, test the wiring connections to make sure the unit is connected properly and the system works.
- Use only the parts included with the unit to ensure proper installation. The use of unauthorized parts can cause malfunctions.
- Consult with your nearest dealer if installation requires the drilling of holes or other modifications to your vehicle.
- Install the unit where it does not interfere with driving and cannot injure passengers during a sudden or emergency stop.
- If the installation angle exceeds 30° from horizontal, the unit might not give optimum performance.
- Avoid installing the unit where it will be subjected to high temperatures from direct sunlight, hot air, or from a heater, or subject to excessive dust, dirt or vibration.

DIN Front Mount

1. Slide the mounting sleeve off of the chassis if it has not already been removed. If it is locked into position, use the removal keys (supplied) to disengage it. The removal keys are depicted in "Removing the Unit" on page 3.
2. Check the dashboard opening size by sliding the mounting sleeve into it. If the opening is not large enough, carefully cut or files as necessary until the sleeve easily slides into the opening. Do not force the sleeve into the opening or cause it to bend or bow. Check that there will be sufficient space behind the dashboard for the radio chassis.
3. Locate the series of bend tabs along the top, bottom and sides of the mounting sleeve. With the sleeve fully inserted into the dashboard opening, bend as many of the tabs outward as necessary to firmly secure the sleeve to the dashboard.

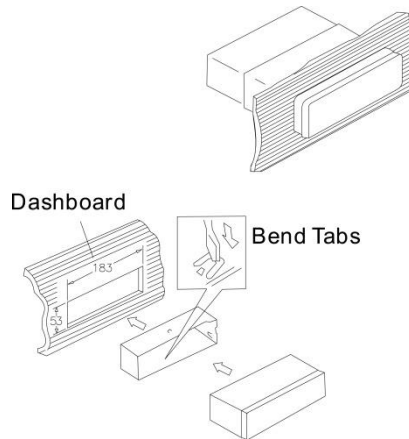

4. Place the radio in front of the dashboard opening so the wiring can be brought through the mounting sleeve.
5. Follow the wiring diagram carefully and make certain all connections are secure and insulated with crimp connectors or electrical tape to ensure proper operation.
6. After completing the wiring connections, turn the unit on to confirm operation (vehicle accessory switch must be on). If the unit does not operate, recheck all wiring until the problem is corrected. Once proper operation is achieved, turn the accessory switch off and proceed with final mounting of the chassis.
7. Carefully slide the radio into the mounting sleeve making sure it is right-side-up until it is fully seated and the spring clips lock it into place.
8. Attach one end of the perforated support strap (supplied) to the screw stud on the rear of the chassis using the hex nut provided. Fasten the other end of the dashboard either above or below the radio using the screw and plain washer provided. Bend the strap, as necessary, to position it. Some vehicle installations provide cavity for rear support. In these applications, place the rubber bushing over the screw stud and insert.
CAUTION: The perforated rear support strap or rear rubber mounting bushing must be used in the installation of the radio. Installation without either may result in damage to the radio or the mounting surface and void the manufacturer's warranty.
9. Test radio operation by referring to the operating instructions for the unit.

Removing the Unit

To remove the radio after installation, remove the plastic end caps, insert the removal keys straight back until they click, and then pull the radio out. If removal keys are inserted at an angle, they will not lock properly to release the unit.

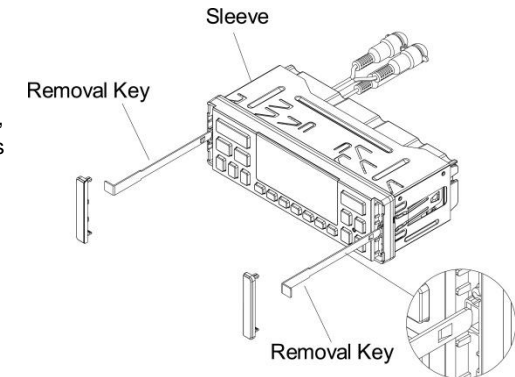

Reconnect Battery

When wiring is complete, reconnect the battery negative terminal.

WIRING

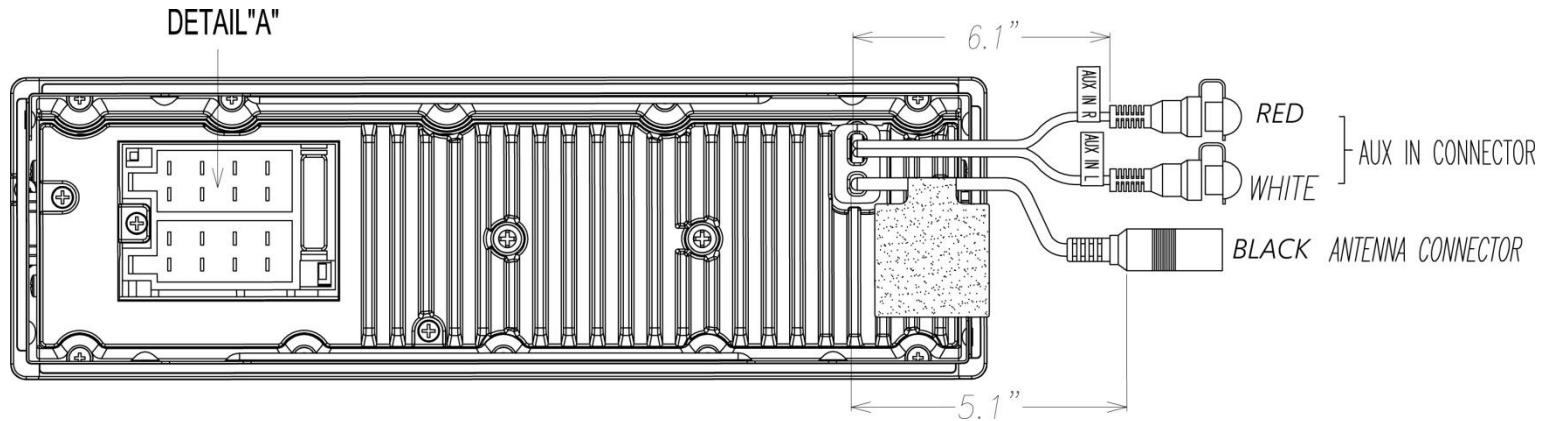

DETAIL A
SHOWN FROM PIN VIEW

PIN NO.	DESCRIPTION
A1	RIGHT REAR SPEAKER (+)
A2	RIGHT FRONT SPEAKER (+)
A3	LEFT FRONT SPEAKER (+)
A4	LEFT REAR SPEAKER (+)
A5	LEFT REAR SPEAKER (-)
A6	LEFT FRONT SPEAKER (-)
A7	RIGHT FRONT SPEAKER (-)
A8	RIGHT REAR SPEAKER (-)
B1	NO CONNECTION
B2	NO CONNECTION
B3	POWER ANTENNA
B4	NO CONNECTION
B5	GROUND
B6	NO CONNECTION
B7	+12V ACC SWITCHED
B8	NO CONNECTION

SEE DETAIL "A"

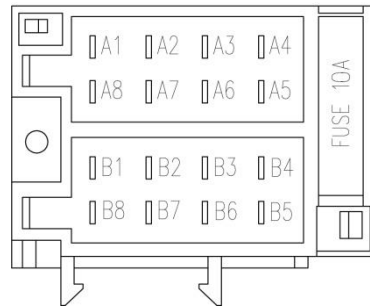

WARNING!
Do not connect the +12VDC ACC switched wire to the battery. This wire **MUST** be connected to the Accessory/ Ignition wire or a +12 volts switched power source.

BASIC OPERATION

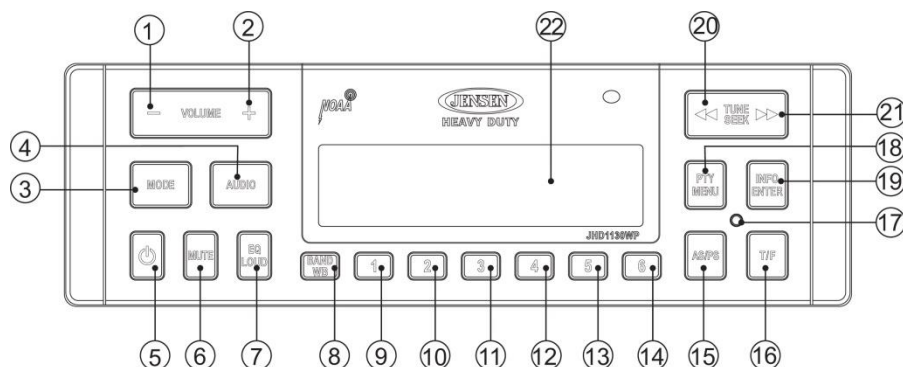

Power On/ Off

Press the power button (5) to turn the unit on or off. The unit will resume at the last mode selected (Tuner, Auxiliary, etc.).

Volume Control

To increase the volume, press the **VOLUME +** button (2). To decrease the volume, press the **VOLUME -** button (1).



The maximum volume setting is 40.

Mute

Press the **MUTE** button (6) to mute the audio output. Press **MUTE** again to restore the audio output to the previous level.

Mode

Press the **MODE** button (3) to select a different mode of operation, as indicated on the display panel. Available modes include the following: Tuner (AM/ FM) > Auxiliary. Tuner is the default source when a prior source is no longer available.

RESET

The reset button should be activated for the following reasons:

- Initial installation of the unit when all wiring is completed

- Function buttons do not operate
- Error symbol on the display

Use a ball point pen or thin metal object to press the **RESET** button (17). This may be necessary should the unit display an error code.

Audio Menu

Press the **AUDIO** button (4) to access the audio menu. You can navigate through the audio menu items by pressing the **AUDIO** button repeatedly. Once the desired menu item appears on the display, adjust that option by pressing the **VOLUME +/-** buttons (2, 1) within 5 seconds. The unit will automatically exit the audio menu after 5 seconds of inactivity. The following menu items can be adjusted.

Bass Level

Press the **VOLUME +/-** buttons (2, 1) to adjust the Bass level range from “-7” to “+7”.

Treble Level

Press the **VOLUME +/-** buttons (2, 1) to adjust the Treble level range from “-7” to “+7”.

Balance

Adjusting Balance controls the relative level between the left and right speakers in each pair. Press the **VOLUME +/-** buttons (2, 1) to adjust the Balance between the left and right speakers from “L12” to “R12”.

Fader

Adjusting Fade controls the relative level between the front and rear speaker pairs. Press the **VOLUME +/-** buttons (2, 1) to adjust the Fader between the rear and front speakers from “R12” to “F12”.

System Menu

1. Press and hold the **PTY/MENU** button (18) for more than 2 seconds to enter the system menu. The first menu item, “KEYBEEP”, will appear on the display.
2. Press the **TUNE/SEEK** ◀◀ or ▶▶ buttons (20, 21) repeatedly to navigate the system menu.
3. Press the **INFO/ENTER** button (19) to select the desired item.
4. Press the **INFO/ENTER** button again to adjust the selected menu item.

The following items can be adjusted:

- **KEYBEEP** (Clk (click) / Bep (beep) / Off): Turn the audible beep On/ Off (heard when functions/buttons are selected).
- **LCDLITE** (1-10): Adjust LCD brightness.
- **TUNING** (USA / EURO): Set frequency spacing for various regions.
- **P-- CLOCK** (1-10 / Off): Adjust LCD brightness in standby mode.
- **CLK FMT** (12Hour / 24Hour): Select 12 or 24 hour display mode.
- **CLK** (HH : MM): Set clock.
 - Press the **INFO/ENTER** button to view the clock set screen.
 - Press the **INFO/ENTER** button to move to the next digit.
 - Press the **TUNE/SEEK** ◀◀ or ▶▶ buttons to adjust the selected digit.

- PREONLY (On / Off): Turn preset-only tuning On/ Off.
- BAT ALRM (Off / On): When ON, the radio will alert when the voltage of vehicle battery is below 10.8 VDC.
- BAT OFF (Off / On): When ON, the radio will automatically turn off when the voltage of vehicle battery is below 10.8 VDC.
- RESET ALL <ENTER>: Press the **INFO/ENTER** button to return the EEPROM to factory default set up values.

Equalizer

Press the **EQ/LOUD** button (7) to choose one of the following pre-defined bass and treble curves: USER > FLAT > ROCK > CLAS(SICAL) > POP.

Loudness

Press and hold the **EQ/LOUD** button (7) to toggle loudness on/ off. When listening to music at low volumes, this feature will boost the bass and treble ranges to compensate for the characteristics of human hearing.

Auxiliary Input

To access an auxiliary device:

1. Connect the portable audio player to the AUX IN Connector on the rear.
2. Press the **MODE** button (3) to select "Auxiliary" mode.
3. Press **MODE** again to cancel "Auxiliary" mode and go to the next mode.

Liquid Crystal Display (LCD)

The current frequency and activated functions are shown on the LCD panel (22).

NOTE: LCD panels may take longer to respond when subjected to cold temperatures for an extended period of time. In addition, the visibility of the characters on the LCD may decrease slightly. The LCD display will return to normal when the temperature increases to a normal range.

Setting the Clock

To set the clock to display the current time, turn the vehicle ignition on and turn the radio on. Press **PTY/MENU** button (18) to enter the system menu and adjust the clock by selecting the "CLK" menu item.

- Press the **INFO/ENTER** button (19) to view the clock set screen.
- Press the **TUNE/SEEK** ◀◀ or ▶▶ buttons (20, 21) to adjust the selected digit.

Press the **INFO/ENTER** button to move to the next digit. The time will become set immediately and normal operation will resume.

Display Modes

Press the **T/F** button (16) to switch between LCD clock display and source display..

TUNER OPERATION

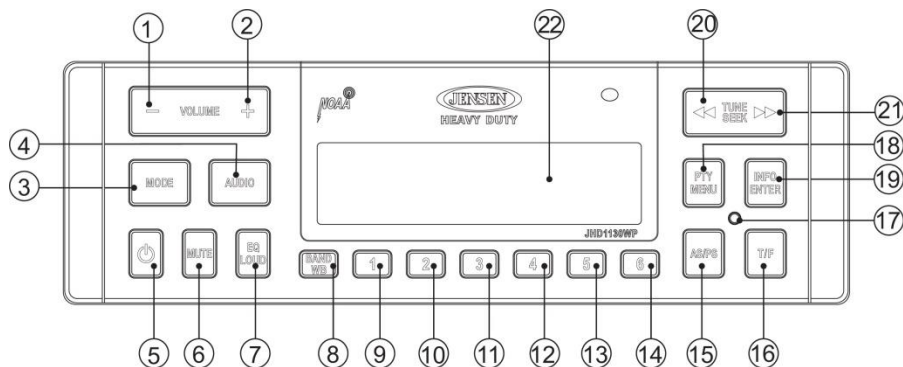

Select a Band

Press the **BAND/WB** button (8) to change between three FM bands and two AM bands.
Press and hold the **BAND/WB** button to access the Weather band (WB).

Manual Tuning

Press the **TUNE/SEEK** ◀◀ or ▶▶ buttons (20, 21) to seek stations up/ down step by step.

Auto Seek Tuning

Press and hold the **TUNE/SEEK** ◀◀ or ▶▶ buttons (20, 21) to automatically seek the next or previous strong station.

NOTE: Seek tuning is not available for weather band channels. Use the up or down tuning buttons to manually select any of the seven available weather band channels.

Preset Stations

Six numbered preset buttons store and recall stations for each band.

Store a Station

Select a band (if needed), then select a station. *Press and hold* a preset button (5-10) for two seconds. The preset number will appear on the LCD.

Recall a Station

Select a band (if needed). Press a preset button (5-10) to select the corresponding stored station.

NOTE: Preset buttons are pre-assigned frequencies in weather band mode.

Automatically Store/ Preset Scan (AS/PS)

Automatically Store

Select an AM or FM band. *Press and hold* the **AS/PS** button (15) for more than 2 seconds to automatically select 18 strong stations (12 for AM). “FM STORE” or “AM STORE” will appear on the screen and the new stations will replace any stations previously stored.

Preset Scan

Select a band. Press **AS/PS** (15) to scan preset stations stored in the current band. The unit will pause for 8 seconds at each preset station. Press **AS/PS** again to stop scanning when the desired station is reached.

RBDS Operation

This unit is equipped to display RBDS (Radio Broadcast Data Service) information if broadcast by the current radio station.

NOTE: Radio stations broadcasting RBDS may not be available in your listening area.

In FM radio mode, press the **PTY/MENU** button (18) to list the following Program Type (PTY) options: ANY / News / Information / Sports / Talk / Rock / Classic Rock / Adult Hits / Soft Rock / Top 40 / Country / Oldies / Soft / Nostalgia / Jazz / Classical / Rhythm and Blues / Soft Rhythm & Blues / Foreign Language / Religious Music / Religious Talk / Personality / Public / College / Weather / Emergency Test / EMERGENCY.

To search for stations in a PTY category:

1. Press the **PTY/MENU** button (18) to view the current PTY category.
2. Press the **TUNE/SEEK** ◀◀ or ▶▶ buttons (20, 21) to move through the list of available categories and select the program type you wish to search.
3. After selecting the desired PTY, press the **INFO/ENTER** button to search the band for broadcasts of this type. “PTY Search” is displayed while the tuner is searching.

NOTE: Performing a PTY search on “ANY” will Seek Tune and stop on any station broadcasting RBDS, regardless of the program type.

Locked/ Unlocked

In AM or FM radio mode, press both **AUDIO** and **TUNE/SEEK** ▶▶ buttons (4, 21) at the same time, then press **2** button (10) to toggle Locked/ Unlocked. When the Locked is on, you cannot use **TUNE/SEEK** ◀◀ or ▶▶ buttons to seek stations. When the Unlocked is on, you can use **TUNE/SEEK** ◀◀ or ▶▶ buttons to seek stations. (default “Unlocked”)

Weather Band Operation

What is the NOAA Weather Radio/ Weatheradio Canada?

NOAA (National Oceanic and Atmospheric Administration) is a nationwide system that broadcasts local weather emergency information 24 hours a day via the National Weather Service (NWS) network. The U.S. network has more than 530 stations covering the 50 states as well as the adjacent coastal waters, Puerto Rico, the U.S. Virgin Islands and the U.S. Pacific Territories. Each local area has its own transmitting station and there are a total of seven broadcasting frequencies used. A similar system is available in Canada under the Weatheradio Canada service administered by Environment Canada.

Tuning to Weatherband

Press and hold the **BAND/WB** button (8) to access the Weatherband. The indication "WB" will appear on the display panel, along with the current number and channel indication: "WB-1", "WB-2", "WB-3", "WB-4", "WB-5", "WB-6" or "WB-7". The seven frequencies are shown in the following table:

WB Frequencies

Frequency (MHz)	Preset
162.400	2
162.425	4
162.450	5
162.475	3
162.500	6
162.525	-
162.550	1

The above table also shows which preset button will access the frequency. Note that one frequency cannot be accessed using a preset button. The frequency can only be reached using the tuning controls.

Use the **TUNE/SEEK** ◀◀ or ▶▶ buttons (20, 21) or the preset buttons to tune to each of the seven channels until you find the weatherband station broadcasting in your area.

How many stations can I expect to receive?

Since the broadcasts are local weather and information, the transmission power is usually very low (much less than standard AM or FM stations) so you will usually receive only one station unless you are on the edge of two or more broadcast signals. The most you will receive will be two or three, and that is rare.

Is it possible I won't receive any stations?

Depending on where you are located, there is a possibility you will receive only a very weak signal or none at all. Also, similar to AM and FM signals, weatherband signals are subject to surrounding conditions, weather, obstructions of the signal by hills or mountains, etc.

CARE AND MAINTENANCE

- Keep the product dry. If it does get wet, wipe it dry immediately. Liquids might contain minerals that can corrode the electronic circuits.
- Keep the product away from dust and dirt, which can cause premature wear of parts.
- Handle the product gently and carefully. Dropping the unit can damage circuit boards and cases, which may cause the product to work improperly.
- Wipe the product with a dampened cloth occasionally to keep it looking new. Do not use harsh chemicals, cleaning solvents, or strong detergents to clean the product.
- Use and store the product only in normal temperature environments. High temperature can shorten the life of electronic devices, damage batteries, and distort or melt plastic parts.

Ignition

The most common source of noise in reception is the ignition system. This is a result of the radio being placed close to the ignition system (engine). This type of noise can be easily detected because it will vary in intensity of pitch with the speed of the engine.

Usually, the ignition noise can be suppressed considerably by using a radio suppression type high voltage ignition wire and suppressor resistor in the ignition system. (Most vehicles employ this wire and resistor but it may be necessary to check them for correct operation.) Another method of suppression is the use of additional noise suppressors. These can be obtained from most CB radio or electronic supply shops.

Interference

Radio reception in a moving environment is very different from reception in a stationary environment (home). It is very important to understand the difference.

AM reception will deteriorate when passing under a bridge or when passing under high voltage lines. Although AM is subject to environmental noise, it has the ability to be received at great distance. This is because broadcasting signals follow the curvature of the earth and are reflected back by the upper atmosphere.

TROUBLESHOOTING

Symptom	Cause	Solution
No power	The vehicle's accessory switch is not on	If the power supply is properly connected to the vehicle's accessory terminal, switch the ignition key to "ACC" or "Run".
	Fuse is blown	Replace the fuse.
No sound	Volume too low or system is muted	Adjust volume to audible level.
	Wiring is not properly connected	Check wiring connections.
The operation keys do not work	Built-in microcomputer is not operating properly due to noise	Press the RESET button.
Cannot tune to radio station, auto-seek does not work	Antenna cable is not connected	Check antenna cable.
	Signals are too weak.	Select a station manually.

SPECIFICATIONS

FM Radio

Frequency Coverage (USA)	87.5 to 107.9 MHz
Frequency Coverage (Europe)	87.5 to 108 MHz
Sensitivity (S/N = 30dB)	2.2 μ V
Image Rejection	>45 dB
Stereo Separation	>25 dB

AM/ MW

Frequency Range (USA)	530-1710 kHz
Frequency Range (Europe)	522-1620 kHz
Sensitivity (S/N=20dB)	21 μ V

General

Operating Voltage	DC 12 Volts
Grounding System	Negative Ground
Speaker Impedance	4-8 ohms per channel
Tone Controls:	
Bass (at 100 Hz)	\pm 10 dB
Treble (at 10 kHz)	\pm 10 dB
Power Output	RMS 15W x 4
Idle/ Standby Current	40mA
Current Drain	10 Ampere Max.
Dimensions	7.4" (W) x 3.6" (D) x 2.3" (H)



ASA Electronics Corporation

www.asaelectronics.com

www.jensenheavyduty.com

©2016 ASA Electronics Corporation

v.042017